



Science

## **NUMERICAL ANALYSIS OF STRUCTURAL ELEMENTS BETWEEN 3D CAD SOLIDWORKS AND CODE\_ASTER**

**Benício de Moraes Lacerda <sup>\*1</sup>, Alex Gomes Pereira <sup>2</sup>**

<sup>\*1</sup> Professor at Porto Velho School of Education and Culture, Brazil

<sup>2</sup> Master in Materials Science and Engineering at Federal University of Amazonas, Brazil

---

### **Abstract**

This study aimed to investigate numerically the validation of the use of the free license program Code\_ Aster, with numerical results of the SolidWorks program. For this, four metal elements were modeled, all of them subjected to the tensile stress, they are: a cylindrical bar, two plates with a hole and a metal console. The objective is to validate the use of a free program for analysis of structural elements in engineering office projects and institutional research to verify if the results obtained from the free program show significant differences in the numerical application of a commercial program. All programs have in their design of analysis the use of the finite element method (FEM). The finite element method (FEM) consists to divide a continuous object into a finite number of parts. This allows a complex problem to be transformed into a set of simple problems (finite element) in addition to solving a set of finite elements by approximations with good precision of the results and to model the problem in a real physical way. It was observed that the numerical results between the SolidWorks program and the free program Code\_ Aster were close with differences of less than 5%, which indicates the reliability of the use of Code\_ Aster for numerical analyzes of structural elements of engineering projects and also in institutional research.

**Keywords:** Numerical Simulations; Finite Element Method; Stress Concentration; Solids Mechanics.

**Cite This Article:** Benício de Moraes Lacerda, and Alex Gomes Pereira. (2019). “NUMERICAL ANALYSIS OF STRUCTURAL ELEMENTS BETWEEN 3D CAD SOLIDWORKS AND CODE\_ASTER.” *International Journal of Research - Granthaalayah*, 7(10), 458-470. <https://doi.org/10.5281/zenodo.3542113>.

---

### **1. Introduction**

For many years man has used empirical knowledge and intuitive skills for elaborate engineering design. Since then, the study of the mechanics of materials, structural analysis and architecture has gradually evolved and, as a result, there has been a formal separation between structural and architectural activities. However, only with the evolution of informatics it was possible for man to develop analytical and numerical solutions closer to the constructive reality.

The technology has brought with it the ability to develop advanced engineering designs, as well as the ability to apply more effective and accurate execution techniques through numerical simulations. In this sense, the engineer must take a critical look at the computationally generated responses, that is, he must have a calculation sensitivity to the proposed problem.

Structural analysis derives from mechanics, which plays a fundamental role in the ability to predict forces and movements in projects from various branches of engineering. The ability of physical and mathematical understanding requires skill to visualize and define materials to be used, as well as to impose true static constraints and practical limitation. This allows to direct and understand the behavior of structures. Thus, both mechanics and structural analysis, physics and mathematical concepts are essential in the innovation of bolder and more accurate designs.

Merian and Kraige (2009) affirms that mechanics deals with the causes and consequences of the effects of forces on objects and allows various research in the areas of robotics, machines, vibrations, stability and structure strength. According to Alves Filho (2012), many engineering structures are complex to be solved by analytical methods, such as based on differential equations the describes the static of structure.

Moaveni (2008) describes that some engineering problems can be solved by mathematical modeling of differential equations subject to a boundary condition. These differential equations derive from fundamental laws and principles of the system nature, whose exact solution reflects the detailed behavior of the system under a given condition. These fundamental laws and principles, according to Alves Filho (2012), obey the three fundamental relationships of structural mechanics: balance of forces, displacement compatibility and law of material behavior.

In the effort to develop an approximate procedure that numerically reproduces the behavior of a structure, the Finite Element Method (FEM) emerged. The FEM presents an approximate solution of the object under study discretized by the assembly of finite size elements. Alves Filho (2012) affirm that this system is subdivided into a finite number of parts or elements. Thus, it becomes possible the numerical analysis of the behavior of each of these finite elements, from the contribution of each one, obtaining the approximate behavior of the entire structure.

The FEM is a calculation model increasingly used in the construction industry, auto, aerospace, aeronautics, naval, telecommunication, water resources, etc. In structural engineering, the application of the FEM refers to the determination of stresses and deformations as well as to predict the structural behavior, such as imposed displacements (foundations) of buildings, dams, bridges, walkways, tunnels. The FEM allows to discretize constructive elements through the finite elements of beam, slab, trusses, walls, foundations and blocks. In the area of solids mechanics, the FEM allow static analysis, vibration study and structural instability through modal analysis in addition to dynamic analysis.

The aim of this study was to evaluate structural models such as plates, bar and metallic console using 3D CAD software SolidWorks and to compare the numerical results obtained by the Code\_Aster free program. Both software is used for numerical simulation in structural mechanics.

## 2. Basic Premises of Finite Element Method

The basic premise for numerical resolution of a complex problem is to divide the domain into a finite number of parts (elements), allowing the contour geometry to be continually circumvented at its nodes or connection points to form a mesh. The mesh consists of a set of elements and nodes (nodal points) that represent the problem domain, as shown in Figure 1.

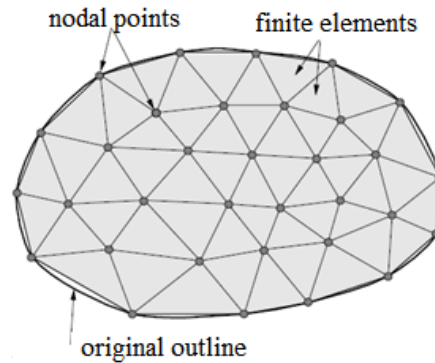


Figure 1: Finite element mesh contained in a plane

Source: Souza (2003)

According to the dimension of the problem (uni, bi or three-dimensional) there are several geometric shapes to compose the finite elements and form the mesh, can be mentioned: bar element, tetrahedral, triangular, quadrilateral, etc., as shown in Figure 2.


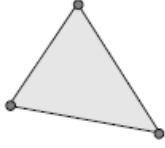
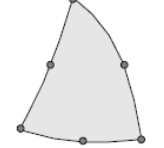
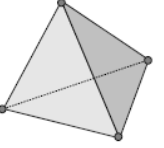

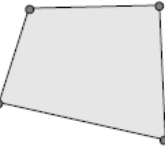
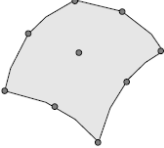
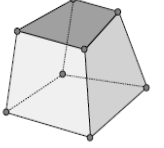
 <p>a) Bar element with two nodes</p>	 <p>b) Three-node triangular element</p>	 <p>c) Six-node triangular element</p>	 <p>d) Four-node tetrahedral element</p>
 <p>e) Bar element with three-node</p>	 <p>f) Four-node quadrilateral element</p>	 <p>g) Nine-node quadrilateral element</p>	 <p>h) Eight-node hexahedral element</p>

Figure 2: Finite Element Types

Source: Souza (2003)

However, when modeling complex geometric contours, different shapes of elements can be combined to form mesh. It is preferable to use regular elements with the same dimensions. For modeling three-dimensional models, the hexagonal element is commonly used. However, in transition zone mesh (Figure 3), the use of regular elements is not always possible, and may require modeling with adjustable elements to the contour of the problem.

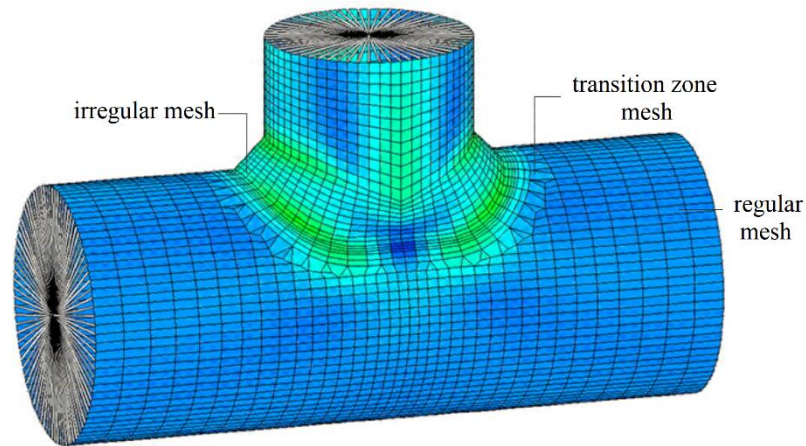


Figure 3: Transition zone mesh

Source: Adapted from N.A Technology (2015)

Alves Filho (2012) affirm the basic equation for the calculation of forces and displacements is given by:

$$[K] \cdot \{u\} = \{F\} \quad (1)$$

$[K]$  is the stiffness matrix of the structure and presents order equal to the number of degrees of freedom;

$\{u\}$  is the nodal displacement vector;

$\{F\}$  It is the vector of forces on the nodes.

The procedure for applying the FEM can be described by:

- 1) Obtain the geometric shape of the object, as well as its material properties, support and loading conditions;
- 2) Divide the object into elements;
- 3) Establish the equilibrium equation:  $[K] \cdot \{u\} = \{F\}$ ;
  - Construct the stiffness matrix according to the geometry of the elements and their material properties;
  - Most force vector components  $\{F\}$  can be calculated according to the loading conditions;
  - Most components of the nodal displacement vector  $\{u\}$  are unknown. Some values, however, can be determined according to the support conditions;
  - The total unknown number of nodal displacements  $\{u\}$  and force  $\{F\}$  must be equal to the total degrees of freedom.
- 4) The equilibrium equations are solved to obtain the nodal displacements of each element;
- 5) The equilibrium equations are solved to obtain the support reactions from the nodal displacements.

### 3. Brief Elasticity Theory Concepts

For an understanding of how an object deforms, consider a three-dimensional infinitesimal element presented in Figure 4, in which each side of the element is subject to a stress perpendicular to the plane (normal stress) and two stresses parallel to the face (shear stresses).

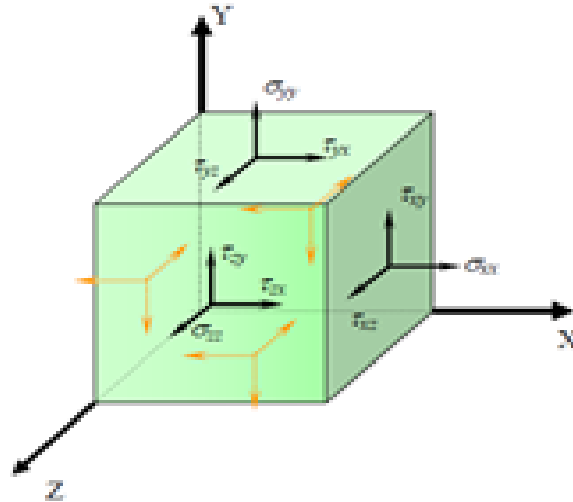


Figure 4: Normal and shear stresses on a three-dimensional infinitesimal element

Source: Gesualdo (2010)

For Lee (2012) in the axial direction, elongation is called longitudinal strain and contraction in the transverse direction, transverse strain. The absolute value of the ratio between the longitudinal strain and transverse strain is called Poisson's ratio. For example, the analysis for an isotropic material, has the same property in all directions, with  $E$  (Young's module of elasticity) and  $\nu$  (Poisson's ratio) of constant values in either direction. The strains produced by each of the stresses are:  $\epsilon_{xx}$ ,  $\epsilon_{yy}$ ,  $\epsilon_{zz}$ ,  $\gamma_{xy}$ ,  $\gamma_{xz}$  and  $\gamma_{yz}$ . With  $\epsilon$  corresponding to longitudinal specific strain and  $\gamma$  transverse specific strain.

The equation that relates stresses and deformations for an isotropic material is given by:

$$\begin{Bmatrix} \sigma_{xx} \\ \sigma_{yy} \\ \sigma_{zz} \\ \tau_{xy} \\ \tau_{yz} \\ \tau_{xz} \end{Bmatrix} = \frac{E}{(1+\nu) \cdot (1-2\nu)} \cdot \begin{bmatrix} 1-\nu & \nu & \nu & 0 & 0 & 0 \\ \nu & 1-\nu & \nu & 0 & 0 & 0 \\ \nu & \nu & 1-\nu & 0 & 0 & 0 \\ 0 & 0 & 0 & \frac{1-2\nu}{2} & 0 & 0 \\ 0 & 0 & 0 & 0 & \frac{1-2\nu}{2} & 0 \\ 0 & 0 & 0 & 0 & 0 & \frac{1-2\nu}{2} \end{bmatrix} \cdot \begin{Bmatrix} \epsilon_{xx} \\ \epsilon_{yy} \\ \epsilon_{zz} \\ \gamma_{xy} \\ \gamma_{yz} \\ \gamma_{xz} \end{Bmatrix} \quad (2)$$

The stress distribution can be analyzed in the stress plane state and the strain plane state, as described by Beer, Johnston and Dewolf (2015).

Figure 5 shows a two-dimensional element with zero stresses in the direction perpendicular to its plane. For the analysis of equations that relate stresses, it is considered that the compressive stresses are negative and the tensile stresses are positive. If the element is formed by material with different properties, it is necessary to characterize  $E_x$ ,  $E_y$ ,  $\nu_{xy}$ ,  $\nu_{yx}$  and  $G$ .

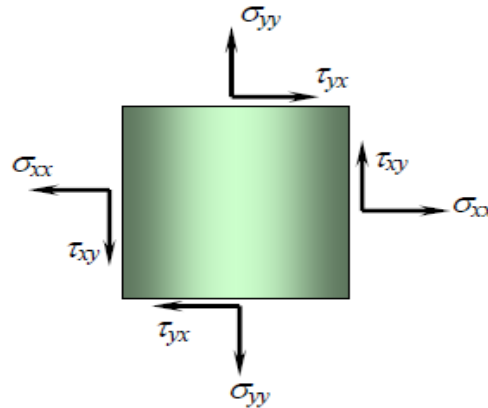


Figure 5: Plane state of stresses applied to an element

Source: Gesualdo (2010)

The values of the modulus of elasticity  $E_x$  and  $E_y$  are obtained from Hooke's Law that relate stress and strain of the material. That is, for each loading moment, there are specific strain, whose values  $E_x$  and  $E_y$  are calculated by the relation  $\sigma / \epsilon$ . Poisson's coefficients correspond to the relation of the transverse strain ( $\epsilon_{yy}$ ) to the loading action by the longitudinal strain ( $\epsilon_{xx}$ ) to the loading, as described in equation 3:

$$\nu_{xy} = -\frac{\epsilon_{yy}}{\epsilon_{xx}} \text{ e } \nu_{yx} = -\frac{\epsilon_{xx}}{\epsilon_{yy}} \quad (3)$$

#### Von Mises Criteria

Von Mises stress is a positive scalar that describes the stress state. Many materials collapse when this stress exceeds a certain value. This rupture criterion was conceived with experimental evidence. It is widely used in predicting ductile material failures.

Von Mises stress is defined in terms of the normal and shear stresses by the equation:

$$\sigma_{Vonmises} = \sqrt{\frac{(\sigma_{xx}-\sigma_{yy})^2+(\sigma_{xx}-\sigma_{zz})^2+(\sigma_{yy}-\sigma_{zz})^2+6\cdot(\tau_{xy}^2+\tau_{xz}^2+\tau_{yz}^2)}{2}} \quad (4)$$

#### 4. About SolidWorks and Code\_Aster

According Dassault Systèmes (2010) SolidWorks is a solid modeling computer-aided design (CAD) and computer-aided engineering (CAE) computer commercial program. SolidWorks is a parametric modeling tool for solids based on the characteristics and properties of each material applied to the solid element. It is also possible to perform simulations by applying loads to the created object and make its change in any modeling process.

For the realization of a complete project, the program divides the creation process into three distinct steps which are: the first step is part modeling and that allows to be saved in the format "SLDPRT". The second step is the assembly of the various parts created and saved in the "ASM" format. Finally, the third step is the creation of the views or drawings (drawing) of the parts and assembly created to be executed.

For Aubry (2013) Code\_Aster is an acronym for Structural Analysis and Thermodynamics for Studies and Research. It is a finite element analysis program that allows simulating problems involving mechanics, thermodynamics and phenomena of all types of analyses such as: linear static or nonlinear dynamics. It is a General Public License (GPL) license program, meaning it is a free program.

### 5. Materials and Methods

This research is a quantitative study with a survey research design with correlational techniques. The elements to be simulated are presented in Table 1. The elements were initially modeled and simulated in the SolidWorks program and then were exported for analysis in the Code\_Aster free license program. The modeled elements were named by EL-1, EL-2, EL-3, EL-4 and corresponds respectively to: cylindrical bar, metal plate with central hole, metal plate with edge hole and a metallic console (Table 1). Following steps of the modeling were performed in SolidWorks and Code\_Aster:

- 1) Definition of the geometric shape of the solid element;
- 2) Application of materials properties;
- 3) Definition of nodal restriction;
- 4) Applying longitudinal loads to solid surfaces;
- 5) Finite element mesh generation;
- 6) Analyses of stress and displacement.

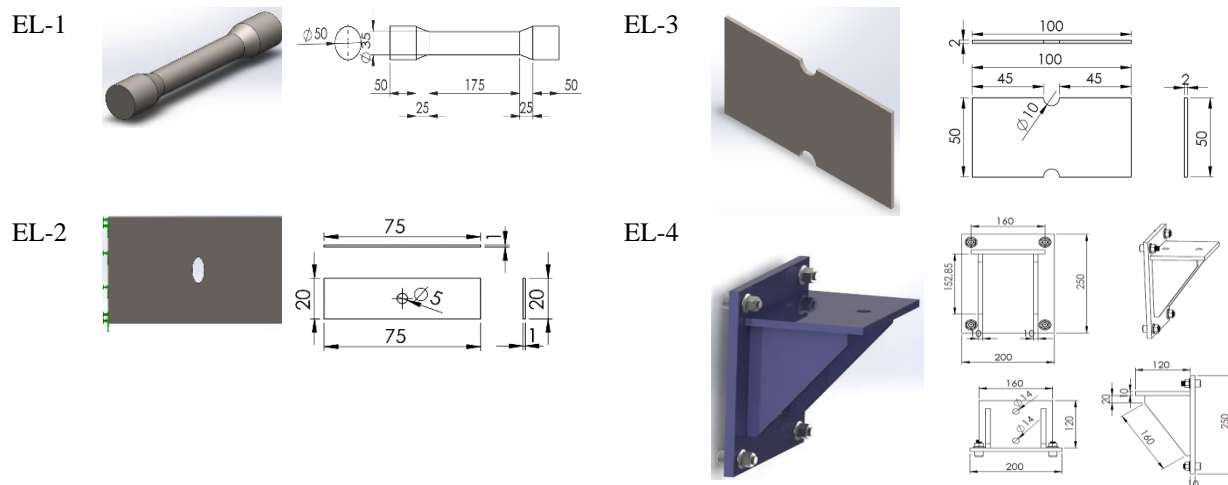


Table 1: Structural elements models. Dimensions in millimeters



Table 2: Presents the physical and mechanical properties of each models.

Model		Material	Density (kg/m <sup>3</sup> )	Young's module - E (GPa)
EL-1	cylindrical bar	Steel ASTM A-36	7850	200
EL-2	metal plate with central hole	Steel alloy	7700	210
EL-3	metal plate with edge hole	Steel alloy	7700	210
EL-4	metallic console	Cast steel alloy	7300	190

Table 2 – Material, density and Young's module E of the models

Table 3: Presents the yield stress, Poisson's ratio and load used in the numerical simulations of the models.

Model	Yield stress – $f_y$ (MPa)	Poisson's ratio - $\nu$	Traction Load (kN)
EL-1	250	0,26	100
EL-2	620	0,28	0,5
EL-3	620	0,28	10
EL-4	241	0,26	120

Table 3 – Yield stress, Poisson's ratio and Loads applied on the models

## 6. Results and Discussions

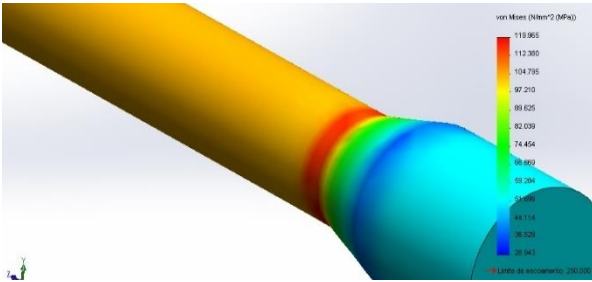
This section presents the results of Von Mises stresses and displacements obtained for numerical models. Table 4 presents the maximum Von Mises stress and displacements results between the software SolidWorks and Code\_Aster.

Table 4: Maximum Von Mises stress and displacements results

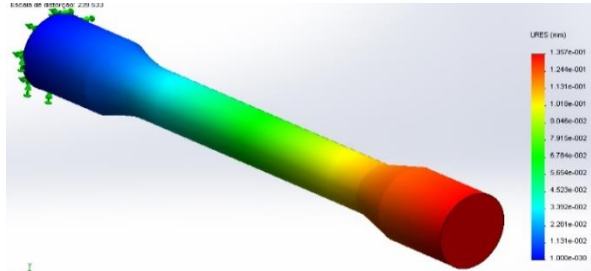
Software	Results	EL-1	EL-2	EL-3	EL-4
SolidWorks	Max. Von Mises Stress (MPa)	119,96	79,08	298,40	216,87
	Max. Displacement (mm)	$1,357 \times 10^{-01}$	$9,285 \times 10^{-03}$	$5,228 \times 10^{-02}$	$7,154 \times 10^{-02}$
Code_Aster	Max. Von Mises Stress (MPa)	123,40	79,30	286,20	281,20
	Max. Displacement (mm)	$1,350 \times 10^{-01}$	$9,282 \times 10^{-03}$	$4,980 \times 10^{-02}$	$6,612 \times 10^{-02}$

Figures 6 show the Von Mises stresses and displacements for the EL-1 model obtained, respectively, by SolidWorks and Code\_Aster. Both results were similar with lower values of Von Mises stresses at the extremities and higher stresses in the transition region from the central part to the cone trunk of the model. The maximum displacements to the bar occurred in its free end, in red color, with zero translation in the support region (blue color).

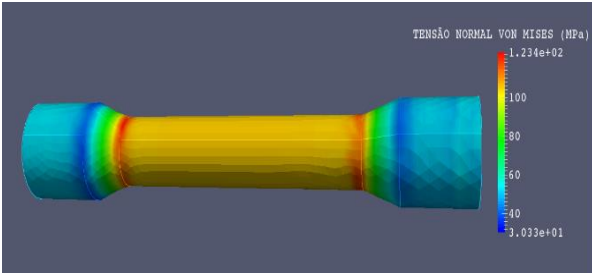




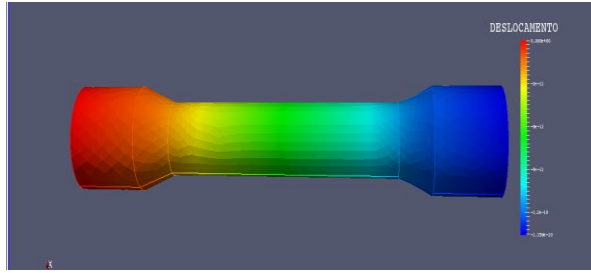
a) SolidWorks – Maximum value of Von Mises stress is 119,96 MPa



b) SolidWorks – Maximum value of displacement is  $1,357 \times 10^{-01}$  mm



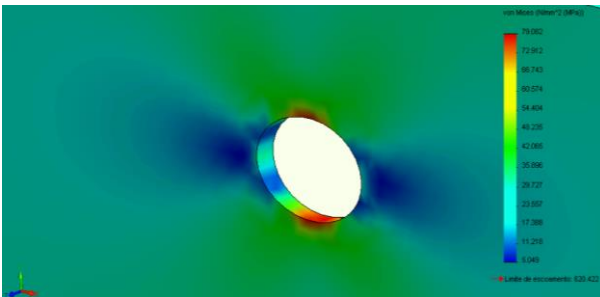
c) Code\_Aster – Maximum value of Von Mises stress is 123,40 MPa



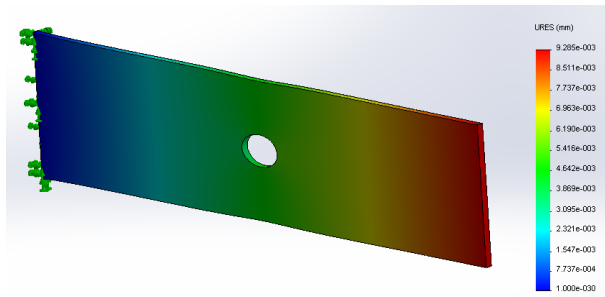
d) Code\_Aster – Maximum value of displacement is  $1,350 \times 10^{-01}$  mm

Figure 6 – Numerical results of EL-1 model

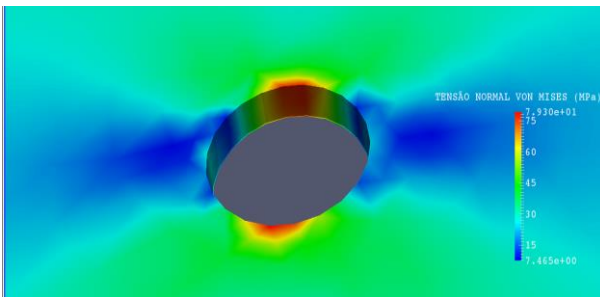
Figures 6: Show the Von Mises stresses and displacements for the EL-2 model obtained, respectively, by SolidWorks and Code\_Aster.



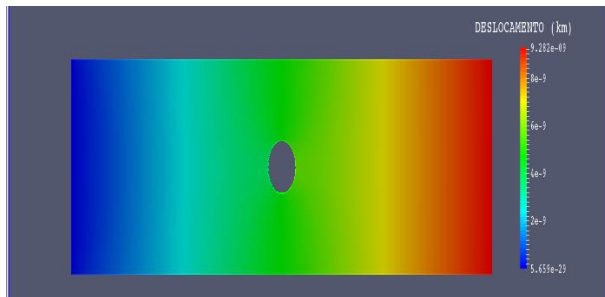
a) SolidWorks – Maximum value of Von Mises stress is 79,08 MPa



b) SolidWorks – Maximum value of displacement is  $9,285 \times 10^{-03}$  mm



c) Code\_Aster – Maximum value of Von Mises stress is 79,30 MPa

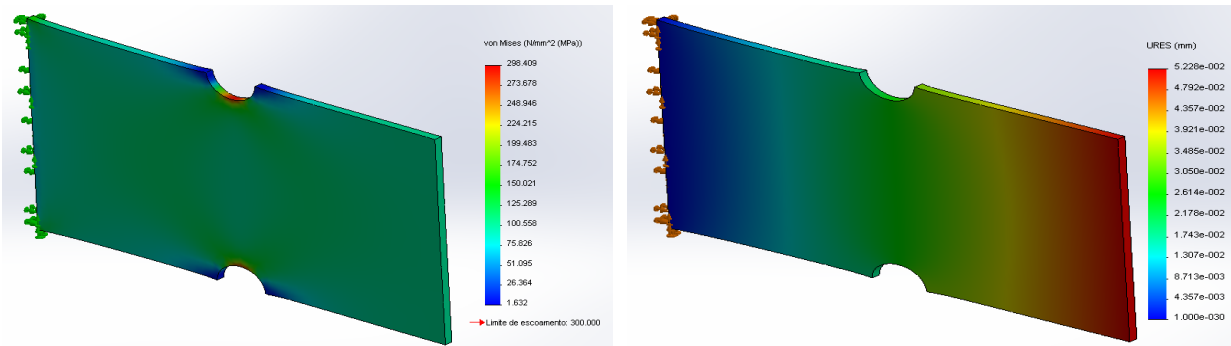


d) Code\_Aster – Maximum value of displacement is  $9,282 \times 10^{-03}$  mm

Figure 7: Numerical results of EL-2 model

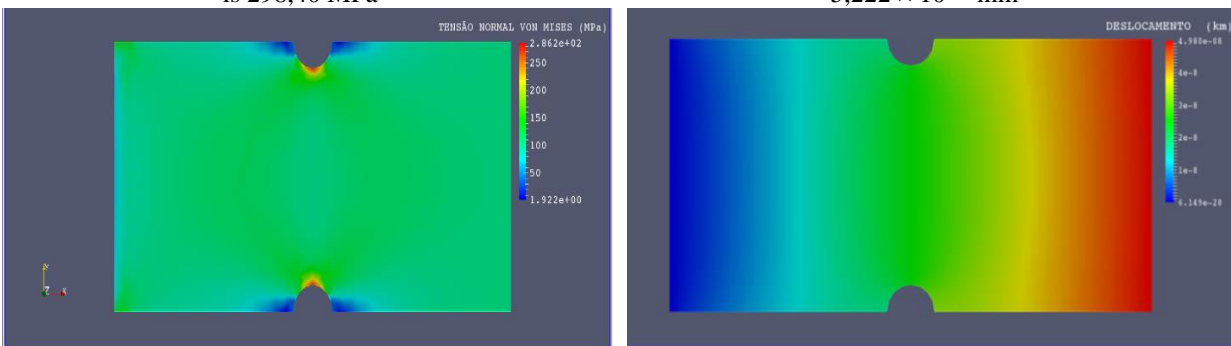
The similarity of mechanical behavior presents can be observed between the two programs, with maximum values of stress in the region of holes and maximum displacements at the edges of the model.

Figure 8 show the Von Mises stresses and maximum displacements for model EL-3 (metal plate with edge holes).



a) SolidWorks – Maximum value of Von Mises stress is 298,40 MPa

b) SolidWorks – Maximum value of displacement is  $5,222 \times 10^{-02}$  mm



c) Code\_Aster – Maximum value of Von Mises stress is 286,20 MPa

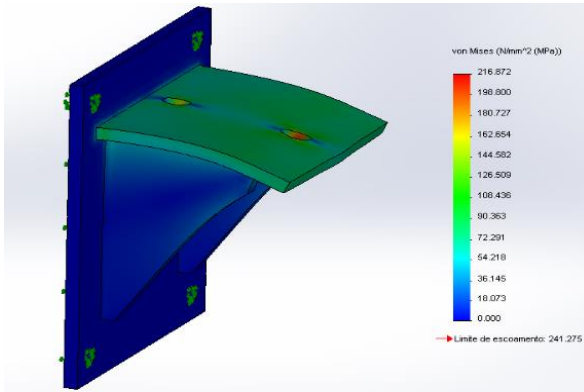
d) Code\_Aster – Maximum value of displacement is  $4,980 \times 10^{-02}$  mm

Figure 8: Numerical results of EL-3 model

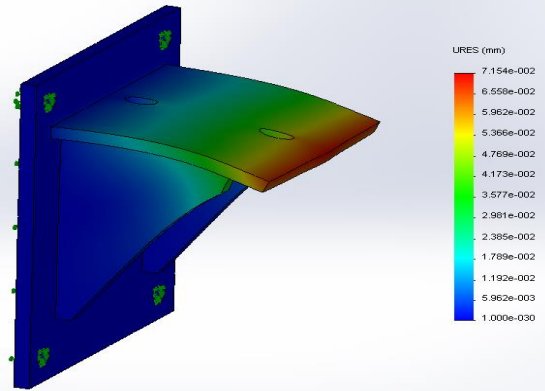
In the EL-3 model both programs showed the same behavior with similar values for Von Mises stresses and displacements.

The numerical results of the console (EL-4 model) are presented by Figure 9. For this model, there is a more significant difference in stress results when comparing the simulation in SolidWorks with the free program Code\_Aster.

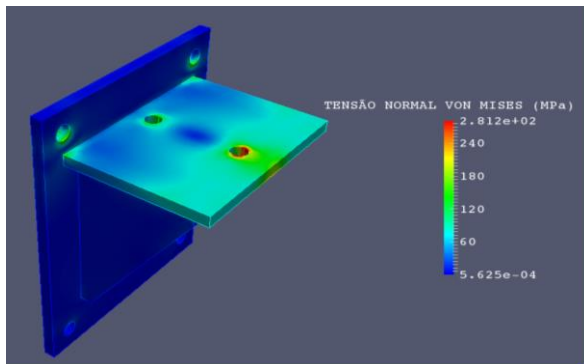
This indicates that an improvement in the mesh used in the numerical solution should be performed, despite the same mechanical behavior presented by both programs. The results shows stress concentration in the hole region and maximum displacement at the console end.



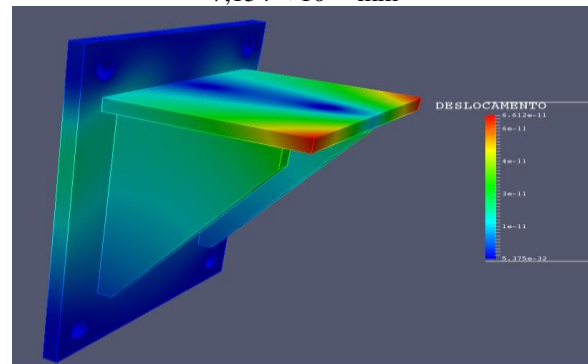
a) SolidWorks – Maximum value of Von Mises stress is 216,87 MPa



b) SolidWorks – Maximum value of displacement is  $7,154 \times 10^{-02}$  mm



c) Code\_Aster – Maximum value of Von Mises stress is 281,20 MPa



d) Code\_Aster – Maximum value of displacement is  $6,612 \times 10^{-02}$  mm

Figure 9: Numerical results of EL-4 model

Table 5: Presents the percentage difference in numerical results between programs.

Model	Difference in numerical results (%)	
	Máximo Von Mises stress	Máximo displacement
EL-1	2,86 %	0,51 %
EL-2	0,27 %	0,03 %
EL-3	4,26 %	4,97 %
EL-4	29,66 %	8,19 %

Table 5 - Difference in numerical results between SolidWorks and Code\_Aster

## 7. Conclusions

In this work are studied results of stress and displacements of four 3D CAD models: cylindrical bar, metal plate with center hole, metal plate with edge hole and metallic console for beam support. The models were submitted to numerical analyzes whose material properties and defined loading were applied as described in tables 2 and 3 of this study. The numerical simulations were performed in programs that adopt FEM and describe Von Mises stresses and its displacements results. During the simulations there are numerous factors that can bring more accurate results with the application of the finite element method. An example of this is the refinement in the model mesh, where it is possible to specify the size and improve mesh in the transition zone. Finally, the main conclusions of this work are aligned below:

- 1) In terms of stress, all elements analyzed presented satisfactory percentage difference between numerical values results. However, special attention in the formation and choice of mesh element type should be given to the EL-4 model, which requires greater care as to its result reliability. To overcome numerical errors, it is possible to apply the following results convergence methods in finite element method programs:
  - Adaptive method h, which tries to automatically improve the results of static studies by estimating errors in the field of stresses and displacements. This method allows progressively refining the mesh in regions with large errors until reaching a level estimated accuracy or convergence;
  - Perform iterations through the Adaptive Method p that increases the polynomial order of mesh elements to improve results in areas with large errors;
- 2) It is observed in Table 5 that the numerical results between the SolidWorks program and the free program Code\_Aster were close with differences below 5 %. This indicates the reliability of using free numerical program like Code\_Aster for analysis of structural elements;
- 3) The major difference among the programs in relation to the Von Mises stress analysis was in the EL-4 model with 29.66%. This difference requires mesh refinement in the near hole regions. However, in terms of displacement this percentage was low 8.19% but higher than the numerically acceptable one that is 5 %.
- 4) Finally, although a larger number of simulations can better validate the behavior of the studied models, it is necessary to have a numerical study that takes into account a more realistic behavior of the set, such as the physical nonlinearity of the materials involved, since the models were simulated by linear static analysis. It is worth noting that the numerical results were conservative.

## References

- [1] Albry, J.P. Beginning with Code\_Aster. A practical introduction to finite element method using Code\_Aster Gmsh and Salome. Paris: FramaBook, 2013.
- [2] Alves Filho, A. Elementos Finitos. A Base da Tecnologia CAE. 5. ed. São Paulo: Érica, 2012.
- [3] Beer, F. P.; Johnston, E. R.; Dewolf, J. T. Resistência dos Materiais. 4. ed. São Paulo: McGraw-Hill do Brasil, 2006.
- [4] Dassault Systèmes. Instructor's Guide to Teaching SolidWorks® Software. Massachusetts, 2010.
- [5] GESULADO, F. A. R. **Notas de Aula: Método dos Elementos Finitos**. Faculdade de Engenharia Civil, Universidade Federal de Uberlândia (FECIV-UFU), 2010. Disponível em: <<http://www.feciv.ufu.br/central-de-conteudos/links/2017/05/area-do-prof-francisco-gesualdo>>. Acesso em: 11 nov. 2016.
- [6] Huang Lee, H. Finite Element Simulations With Ansys WorkBench 14: Theory, Applications, Case Studies. Taiwan: SDC Publications, 2012.
- [7] N.A. Tecnologia. Treinamentos em Análise de Flexibilidade em Tubulações Utilizando o Software Rohr2. São Paulo, 2015. Disponível em <<https://natecnologia.files.wordpress.com/2013/06/rohr2.jpg>> Acesso em: 08 fev. 2017.
- [8] Meriam, J. L., Kraige, L. G. Mecânica para Engenharia. 6. ed. Rio de Janeiro: LTC, 2009.
- [9] Moaveni, S. Finite Element Analysis: Theory and Application with ANSYS. 3. ed. New Jersey: Pearson, 2008.
- [10] Souza, R. M. O Método dos Elementos Finitos Aplicado ao Problema de Condução de Calor. Departamento de Engenharia Civil, Universidade Federal do Pará, 2003. Disponível em:

<[http://www.ufpa.br/nicae/integrantes/remo\\_souza/TrabPublicados/Apostilias/ApostilaElementosFinitosNiCAE.pdf](http://www.ufpa.br/nicae/integrantes/remo_souza/TrabPublicados/Apostilias/ApostilaElementosFinitosNiCAE.pdf)>. Acesso em: 02 fev. 2017.

---

\*Corresponding author.

*E-mail address:* benicio\_lacerda@ hotmail.com