



Science

NAVIGATION OF MOBILE ROBOT- ALGORITHM FOR PATH PLANNING & COLLISION AVOIDANCE- A REVIEW

V.Keerthana¹, C.Kiruthiga², P.Kiruthika³, V.Sowmiya⁴, R.Manikadan^{*5}

^{1, 2, 3, 4} Student, A.V.C College of Engineering, Manampandal, TamilNadu, India

^{*5} Assistant Professor, A.V.C College of Engineering, Manampandal, TamilNadu, India

DOI: <https://doi.org/10.5281/zenodo.263936>

Abstract

The field of autonomous mobile robotics has recently gained many researchers' interests. Due to the specific needs required by various applications of mobile robot systems, especially in navigation, designing a real time obstacle avoidance and path following robot system has become the backbone of controlling robots in unknown environments. The main objective of our project is applications based mobile robot systems, especially in navigation, designing real time obstacle avoidance and path following robot system has become the backbone of controlling robots in unknown environments. The main objective behind using the obstacle avoidance approach is to obtain a collision-free trajectory from the starting point to the target in monitoring environments. The ability of the robot to follow a path, detects obstacles, and navigates around them to avoid collision. It also shows that the robot has been successfully following very congested curves and has avoided any obstacle that emerged on its path. Motion planning that allows the robot to reach its target without colliding with any obstacles that may exist in its path. To avoid collision in the mobile robot environment, providing a path planning & line following approach. Line following, path planning, collision avoidance, back propagation, improved memory, detecting long distance obstacles. Cheap and economical than the former one. Also work with back propagation technique.

Keywords: Collision Avoidance; Path Planning; Robotics Control; Webots; Mobile Robot; E-Puck.

Cite This Article: V.Keerthana, C.Kiruthiga, P.Kiruthika, V.Sowmiya, and R.Manikadan. (2017). "NAVIGATION OF MOBILE ROBOT- ALGORITHM FOR PATH PLANNING & COLLISION AVOIDANCE- A REVIEW." *International Journal of Research - Granthaalayah*, 5(1), 198-205. <https://doi.org/10.5281/zenodo.263936>.

1. Introduction

There has been a spurt of interest in recent years in the area of autonomous mobile robots that are considered as mechanical devices capable of completing scheduled tasks, decision-making and

navigating without any involvement from humans. This has brought up some serious concerns about the interaction between mobile robots and the environment, including autonomous mobile navigation, path planning, obstacle avoidance etc. Deploying autonomous mobile robots is coupled with the use of external sensors that assist in detecting obstacles in advance.

The mobile robot uses these sensors to receive information about the tested area through digital image processing or distance measurements to recognize any possible obstacle. Several ways of testing the surroundings have been introduced in the literature of path planning of mobile robot. Although ultrasonic sensors, positioning systems and camera are most widely used to move in an unknown environment, they are not the suitable solution to facilitate and neaten the robot structure.

Therefore, some infrared sensors are used to follow an optimum non-collision path from source to destination according to particular performance objectives. In addition, path planning in mobile robot can be divided into two types based on the robot's knowledge of the environment. In the global path planning where the environmental information is predefined, the global path planning is also called static collision avoidance planning and the local path planning where the environmental information is not pre known, the local path planning is also called dynamic collision avoidance planning.

The local path planning is more demanding than global path planning since it has a changeable direction and requires a prediction of dynamic obstacle position at every time step in order to achieve the requirement of a time-critical trajectory planning. The local path planning also considers some kinds of measurements regarding the dimensions of the moving obstacle such as position, size and shape through sensors as fast as possible to avoid arisen unknown obstacle while the robot is moving toward goal state.

The most well-known sensors used to follow a specific path while detecting obstacles and measuring the distance between robots and objects are infrared, ultrasonic, and laser sensors. Given the specific needs required by different applications of mobile robot especially in navigation, it is crucial to develop an autonomous robotic system that is capable of avoiding obstacles while following the path in real time applications.

Consequently, an efficient collision avoidance and path following technique is essential to assure intelligent and effective autonomous mobile robot system. This paper presents the results of a research aimed to develop a new technique for line following an obstacle avoidance relying on the use of low cost infrared sensors, and involving a reasonable level of calculations, so that it can be easily used in real time control applications with microcontrollers.

2. Objectives

The main objective of our project is applications of mobile robot systems, especially in navigation, designing real time obstacle avoidance and path following robot system has become the backbone of controlling robots in unknown environments. The main objective behind using the obstacle avoidance approach is to obtain a collision-free trajectory from the starting point to the target in monitoring environments.

The ability of the robot to follow a path, detects obstacles, and navigates around them to avoid collision. It also shows that the robot has been successfully following very congested curves and has avoided any obstacle that emerged on its path. Motion planning that allows the robot to reach its target without colliding with any obstacles that may exist in its path.

3. Methodology

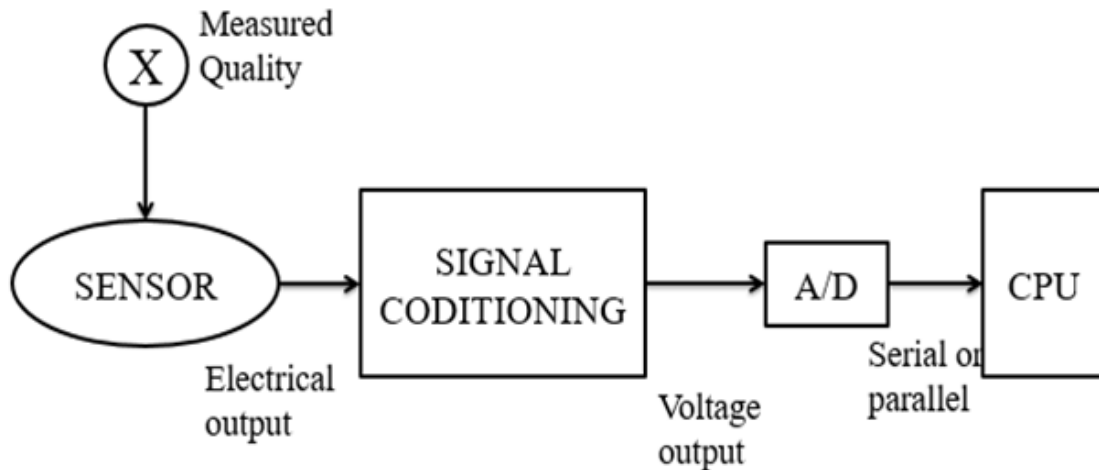

Figure 1: Methodology

- At first the quality of the obstacle is measured using the various sensors placed in the mobile robot. The sensors such as the ultrasonic sensor, infrared sensor and the proximity sensors are used here. These sensors provide the details about the distance from the mobile robot to the obstacle, nature of the obstacle, the shortest path can be followed by the robot, and the destination line is followed or not.
- The electrical output from the sensor is then given to the signal conditioning system, where the electrical output is transferred as the voltage output. The voltage output taken from the signal conditioning is given to the analog to digital signal converter the voltage here converted is helpful in calculating the distance to navigate around the obstacle. This information are stored in the CPU and loaded to the mobile robot and tested.
- Robot motion planning in an unknown environment is always been the main research focus in the mobile robotics area due to its practical importance and the complex nature of the problem. Several collision avoidance and line following techniques have been introduced lately. Each of these techniques was developed to be used in specific applications for the purposes of education, entertainment, business and so on. The ability to detect obstacles in real time mobile robotics systems is a very critical requirement for any practical application of autonomous vehicles.
- The main objective behind using the obstacle avoidance approach is to obtain a collision-free trajectory from the starting point to the target in monitoring environments. There are two types of obstacles: static obstacle, which has a fixed position and requires a priori knowledge of the obstacle; dynamic obstacle, which does not require any prior knowledge of the motion of the obstacle and has uncertain motion and patterns (moving objects). Indeed, detecting dynamic obstacles is more challenging than detecting static

obstacles since the dynamic obstacle has a changeable direction and requires a prediction of the obstacle position at every time step in order to achieve the requirement of a time-critical trajectory planning.

- Moreover, Path tracking is a major aspect of mobile robotics systems that is expected to be widely used in industries and airports to enhance the automatic transportation procedure. In general, the line-following technique is used to track a predefined path with zero steady state error [6]. In terms of the research literature, there have been a number of techniques proposed and studied which addressed collision avoidance and line-following approaches in mobile robotics systems.

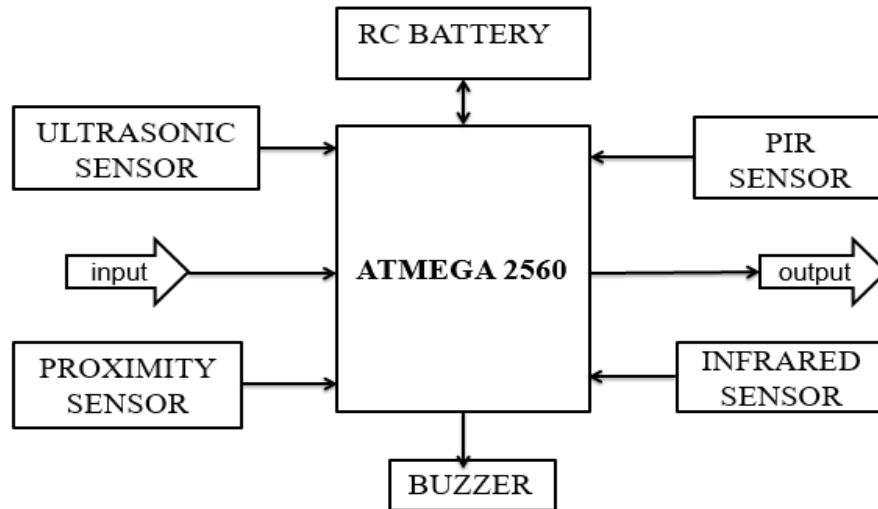

Figure 2: Block diagram

3.1. Collision Avoidance Approach

- Many collision avoidance algorithms have been proposed in the literature of robotics motion planning that allow the robot to reach its target without colliding with any obstacles that may exist in its path. Each algorithm differs in the way of avoiding static/dynamic obstacles.
- The vector field histogram (VFH) is a real-time obstacle avoidance method that uses the two-dimensional Cartesian histogram grid to perform a two-stage data reduction process. First, it converts the two-dimensional histogram to a one-dimensional polar histogram. Second, it selects the most suitable sector with low polar density and calculating the steering angle in that direction.
- A known problem of the VFH is that the robot can only detect static obstacles. The Artificial Potential Field (APF) is present. The algorithm is used to find the shortest path between the starting and target points. The obstacle produces a repulsive force to repel the robot while the target produces an attractive force to attract the robot. That is, the total force on the robot can be calculated based on the attractive and repulsive forces.
- Accordingly, this approach is very sensitive to local minima in case of a symmetric environment. Another obstacle avoidance method is the Bug algorithm where the robot follows the boundary of each obstacle in its way until the path is free.

- The robot then restarts moving toward the target without taking into account any other parameters. There are some significant shortcomings in the Bug algorithm. To illustrate, the algorithm does not consider any other obstacles during the edge detection process. Also, it only considers the most recent sensor readings that might be affected by sensor noise.

3.2.Line Following Approach

- Various methods have been proposed as solutions for line following problems that generally include line-following, object-following, path tracking and so on. The line follower in robotics is simply an autonomous mobile robot that detects a particular line and keeps following it. This line can be as visible as a black line in a white area or as invisible as a magnetic field. Line following in mobile robots can be achieved in three basic operations.
- First, capturing the line width by camera (image processing) or some reflective sensors mounted at the front of the robot. Second, adjusting the robot to follow the predefined line by using some infrared sensors placed around the robot. Third, controlling the robot speed based on the line condition. Bakker et al. proposed a new technique for path following control for mobile robotics systems that sets up the robot to navigate autonomously along its path. The robot utilizes a real time Kinematic Differential Global Positioning System to determine both the position and orientation that correspond to the path.
- The performance of the control shows sufficient results when tested on different paths shapes including a step, ramp, and headland path. Another type of line following technique is described, where the mobile robot is able to choose a desired line among multiple lines autonomously. This robot can detect not only black and white colors but also can differentiate between multiple colors.
- Each line has a specific color and the robot can select the desired color to reach its destination. With this technique, the robot is also able to follow very congested curves as it moves toward its target.
- Another path following approach was introduced, where it relies on the use of digital image processing techniques to track the robot path. It uses computer vision as its main sensor (web cam) for surveying the environment. Moreover, the Proportional-Integral-Derivative control algorithm is also employed to adjust the robot on the line. The demonstrated approach proved its robustness against darkness, camera distortion and lighting.
- Several other obstacle avoidance and line following approaches are suitable for real-time applications but will not be discussed here due to space limitations. Among the reported approaches, the proposed one is unlike any other simple technique. This approach is intended to develop a line follower robot that has the ability to detect and avoid any obstacles that emerges on its path. The mobile robot is equipped with multiple sensors, and a microcontroller that is used to receive information about the surrounding area and then make a decision based on the sensors readings.
- In this brief, a fairly general technique is developed that has components of formation development, line follower and obstacles detection. The contribution of this work relies

on the use of low-cost infrared sensors, so that it can be easily used in real-time robotic applications.

- The controller receives input values directly from the infrared sensors. The robot controller applies the line follower (LFA) and collision avoidance (CAA) approaches. The line follower approach (LFA) receives ground sensor readings as input values and, the controller will then issue a signal to the robot to adjust the motor speeds and follow the line; whereas the collision avoidance approach (CAA) receives distance sensor readings as an input value. When an object is detected in front of the robot, CAA is responsible to spin the robot direction and adjust its speed according to the obstacle's position in order to avoid collision.
- By applying both approaches, the robot follows the line and detects obstacles simultaneously. In other words, if an obstacle is detected, the robot must spin around the obstacle until it finds the line again. An efficient algorithm of the proposed technique is developed, to make the robot have the ability to follow the path and avoid obstacles along its way.
- Initialization is needed for the global variables such as the number of distance and ground sensors used (8 distance sensors and 3 ground sensors) and the collision avoidance threshold value before starting the line follower and collision avoidance robot. After identifying the number of sensors used for each type of sensors, enabling these sensors is the next step. After that, for each time step of the simulation, all the eight distance sensors' values and the three ground sensors' values are obtained and. The three ground sensors are responsible for following the line and the motor speeds are adjusted based on these values.
- However, in case of possible collisions, the front distance sensors values are compared with a predefined collision avoidance threshold. Where if one of these sensors reaches the threshold, a front obstacle is detected. Subsequently, the reading of the right and left distance sensors are taken to determine the direction of the robot movement in case of front obstacle, and later compared with the threshold to check for detected right/left obstacle.
- When the robot's path is determined, the left and right motor speeds are adjusted accordingly. After avoiding the obstacle, the robot will return to the line and continue following its path.

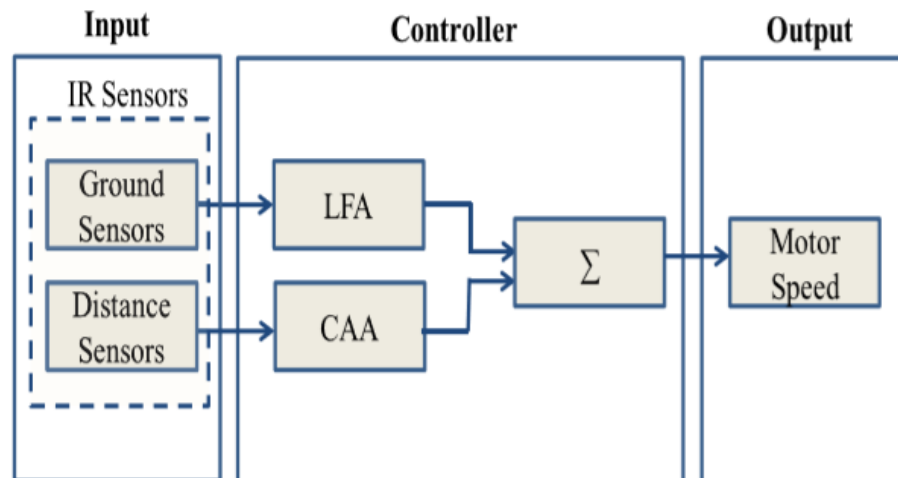

4. Findings

4.1.Distance Sensors Data Analysis

- The e-puck is equipped with 8 distance sensors (Infrared sensors) for collision avoidance around environment. These sensors have values varying from 0 to 2000, where 1000 or more means that the obstacle very close so the e-puck should avoid it accordingly.
- Various sensor measurements have been taken at different simulation times. At the beginning of the simulation (3 seconds of the simulation time) where all 8 distance sensors have low values (50 or less) due to no presence of obstacles along the robot path.
- However, once one of these 8 sensors detects an obstacle, their values increase to 1000 or more. Distance sensor 1 and 8 (the front sensors) have higher values than the remaining sensors (especially the left front sensor has more than 1000). This indicates that there is an obstacle in front of the robot.
- According to the proposed algorithm, when one of the distance sensors reaches the threshold, the robot will avoid the obstacle and move around it to recover its path and, summarize the distance sensor readings once the robot returns to the line. It also shows that at 35 and 40 seconds of the simulation time, all sensor readings are low which means that there is no obstacle in front or around the robot. At 64 seconds of the simulation time, another obstacle is detected with one of the front sensors which reaches the threshold and the sensor measurements are shown at 1 minute and 13 seconds, and 1 minute and seconds respectively.

4.2.Ground Sensors Data Analysis

- The e-puck robot is also equipped with three ground sensors which are infrared sensors facing the ground. Their role is to detect the black line in a white surface in order to guide the robot. After obtaining the ground sensor readings, is computed, this is the difference between the right and left ground sensors. After this, the left and right motor speeds are adjusted accordingly.

5. Real Time Usage

- Industries and airports.
- Enhancing automatic transportation.
- Follow very congested curves.
- Back propagation.
- Military purposes.
- Under water monitoring.

6. Conclusions

Recently, mobile robot navigation in an unknown environment has been the research focus in the mobile robot intelligent control domain. In this paper, we developed a line follower robot that has the ability to detect and avoid any obstacles that emerge on its path. It depends on the use of

low-cost infrared sensors (distance sensors and ground sensors), that are used to measure and obtain the distance and orientation of the robot.

References

- [1] L. E. Zarate, M. Becker, B. D. M. Garrido, and H. S. C. Rocha, "An artificial neural network structure able to obstacle avoidance behavior used in mobile robots," in Proc. IEEE 28th Annu. Conf. Ind. Electron. Soc., Nov. 2002, pp. 2457–2461.
- [2] S. X. Yang and C. Luo, "A neural network approach to complete coverage path planning," IEEE Trans. Syst., Man, Cybern. B, Cybern., vol. 34, no. 1, pp. 718–724, Feb. 2004.
- [3] I. Ullah, F. Ullah, Q. Ullah, and S. Shin, "Integrated tracking and accident avoidance system for mobile robots," Int. J. Control, Autom. Syst., vol. 11, no. 6, pp. 1253–1265, 2013.
- [4] A. Mammeri, T. Zuo, and A. Boukerche, "Extending the detection range of vision-based driver assistance systems application to pedestrian protection system," in Proc. IEEE Glob. Commun. Conf. GLOBECOM, Austin, TX, USA, Dec. 2014, pp. 1358–1363.
- [5] D. Zhou, "Real-time animal detection system for intelligent vehicles," M.S. thesis, School Elect. Eng. Comput. Sci., Univ. Ottawa, Ottawa, ON, Canada, 2014.
- [6] Z. Debao, W. Jingzhou, and W. Shufang, "Countour based HOG deer detection in thermal images for traffic safety," in Proc. Int. Conf. Image Process. Comput. Vis. Pattern Recognit., Las Vegas, NV, USA, Jul. 2012, pp. 1–6
- [7] K. Briechle and U. D. Hanebeck, "Localization of a mobile robot using relative bearing measurements," IEEE Trans. Robot. Autom., vol. 20, no. 1, pp. 36–44, Feb. 2004.
- [8] S. X. Yang and Q. H. Meng, "Real-time collision-free motion planning of a mobile robot using a neural dynamics-based approach," IEEE Trans. Neural Netw., vol. 14, no. 6, pp. 1541–1552, Nov. 2003.
- [9] J. Minguez and L. Montano, "Nearness diagram (ND) navigation: Collision avoidance in troublesome scenarios," IEEE Trans. Robot. Autom., vol. 20, no. 1, pp. 45–59, Feb. 2004.
- [10] X. Yang, M. Moallem, and R. V. Patel, "A layered goal-oriented fuzzy motion planning strategy for mobile robot navigation," IEEE Trans. Syst., Man, Cybern. B, Cybern., vol. 35, no. 6, pp. 1214–1224, Dec. 2005.

*Corresponding author.

E-mail address: manibharathi85@yahoo.co.in